

HEALTHBOX® GO

INSTALLATION & MAINTENANCE MANUAL



Table of Contents

GENERAL	5
1 • General	6
1.1 • Purpose of this manual.....	6
1.2 • Version control	6
1.3 • Using this manual.....	6
1.4 • Electronic version.....	6
1.5 • Symbols used	7
1.6 • Abbreviations.....	7
1.7 • Definitions	7
INSTALLER	8
2 • Set up and installation (Safety)	9
2.1 • General regulations and safety regulations	9
2.2 • Safety regulations.....	10
2.3 • System in operation	11
2.4 • Specific measures	11
2.5 • Electrical	12
2.6 • Moving parts	12
2.7 • Personal Protective Equipment (PPE).....	13
2.8 • Privacy Statement	13
3 • General description of the Renson Healthbox Go unit.....	14
3.1 • Operating principle	14
3.2 • Installation properties	15
3.3 • Service properties	15
3.4 • Maintaining air quality	15
3.5 • Identification	16
3.5.1 • Identification label	16
3.5.2 • Information to be provided when contacting RENSON®	16
3.6 • Warranty terms and conditions.....	16
4 • Material	17
4.1 • Disposing of the device	17

5 • Ventilation unit description	18
5.1 • Checking the delivery	18
5.2 • General description	19
5.3 • Technical specifications.....	20
5.3.1 • Technical specifications	20
5.3.2 • Control of demand-driven ventilation	20
5.3.3 • Control	20
5.3.4 • Installation	21
5.3.5 • Compatible products	21
5.3.6 • Additional features.....	21
5.3.7 • Graphs.....	22
5.3.8 • Dimensions and weight	23
5.4 • General installation conditions	24
6 • Installation.....	25
6.1 • Preparing the unit for installation	25
6.1.1 • Tools.....	25
6.2 • Mounting the unit.....	25
6.3 • Installing air ducts.....	26
Acoustics	27
6.4 • Installing extraction valves	28
6.5 • Extraction of polluted air to outside.....	29
6.6 • Connecting pipes to Healthbox Go.....	29
6.7 • Connecting the Healthbox Go	30
6.7.1 • Healthbox Go PCB.....	30
6.7.2 • Connecting to mains voltage.....	31
6.7.3 • Connecting 3-way switch (XVK3).....	32
7 • Starting up the Healthbox Go	34
7.1 • What to do before adjusting the settings.....	34
7.1.1 • Settings using the push buttons	34
7.1.2 • Adjusting the nominal flow rate using the buttons	35
7.1.3 • Adjusting the standby flow rate using the buttons	36
7.1.4 • Adjusting the humidity sensitivity using the buttons	36
7.1.5 • Adjusting the CO ₂ threshold.....	37
7.1.6 • Adjusting the nominal flow rate using the app.....	37
7.2 • Valve settings	39
7.3 • Controlling the set flow rates.....	39
7.4 • Resetting the Healthbox Go	39

USER	40
8 • Using the Healthbox Go	41
8.1 • Using the Sense app.....	41
8.2 • Setting up WPS (Wi-Fi Protected Setup)	44
8.3 • XVK3 switch	44
8.4 • Boost using the button on the unit	44
9 • Device malfunction	45
10 • Maintenance	46
10.1 • Fan unit.....	46
10.2 • Window vents.....	47
10.3 • Living space extraction louvres.....	47
10.4 • Air extraction ducts	47

GENERAL

1 • General

The RENSON® Healthbox Go is a central extraction unit. Fresh air is brought in naturally via window louvres into the dry rooms. Polluted air is extracted mechanically by Healthbox Go from the humid rooms.

This manual consists of 2 parts:

- The **installation manual**: all information needed for installation.
- The **user manual**: guide to operating this device.

1.1 • Purpose of this manual

This manual contains instructions and recommendations for correctly sizing the Renson Healthbox Go and then safely installing, using and maintaining it. Read this manual completely before installing and using the Renson Healthbox Go Unit. The proper functioning of the Renson Healthbox Go largely depends on correct installation and startup.

1.2 • Version control

This Dutch version is the original version. Any other language versions are translations. In case of incompatibility, the Dutch version is the standard version.

1.3 • Using this manual

Structure

This manual starts with a general description of the Renson Healthbox Go. Read these chapters first to familiarise yourself with the function and location of the most important parts.

This is followed by Renson Healthbox Go procedures:

- For installation.
- For calibration.
- For first use and subsequent use.
- For maintenance.

1.4 • Electronic version

This manual is only available electronically as a PDF file.



The PDF file contains bookmarks in the left margin that allow you to quickly click through to the desired information.

Anywhere the cursor changes to a  symbol, you can click on the link to go to the desired information.

 **Keep the manual's "quick start guide" near the unit.**



1.5 • Symbols used

-  **Tip:** non-essential, useful information.
-  **Warning:** failure to perform the procedure correctly may result in undesirable results or damage to the Renson Healthbox Go Unit.
-  **Danger:** failure to perform the procedure correctly may result in personal injury.

1.6 • Abbreviations

The following abbreviations are used in this manual:

Abbreviation	Meaning
CERTIFICATION	
Belgian General Regulations for Electrical Installations (AREI)	Algemeen Reglement op Elektrische Installaties [General Regulations for Electrical Installations]
EMC	Electro-Magnetic Compatibility
SI UNITS AND GENERAL CONCEPTS	
Pa	Pascal, unit for pressure (1 Newton on 1 m ²)
ppm	Parts per million, a measure of concentration
CO ₂	Carbon dioxide, a measure of human presence
VOC	Volatile Organic Components, a measure of pollutants in the home

1.7 • Definitions

The following terms are used in this manual:

Term	Meaning
System C	Ventilation system with natural supply + mechanical extraction of air
Unit	Renson Healthbox Go
Ventilation system	The unit with associated pipes and control elements
Pressure drop	Every pipework system in a home has a characteristic pressure drop (pipe characteristic).
Valves	Adjustable openings that facilitate air extraction in the different rooms.
Extraction	Extracting air from the home
Nominal flow rate Nominal mode	(= C mode or design mode): operation without demand control, at nominal ventilation level (at the set maximum ventilation flow rate). This mode can be used by the installer and/or ventilation reporter to take flow measurements at each extraction vent. Ventilation level = manual mode at 100%.
Demand management	Healthbox Go monitors air quality for CO ₂ , moisture, and VOCs (odour) 24 hours a day. Here, the ventilation level is intelligently and fully automatically adjusted according to the chosen ventilation profile and according to the measured air quality. This is done based on sensors centrally located in the unit, in the mixed air.

INSTALLER

2 • Set up and installation (Safety)

2.1 • General regulations and safety regulations

The unit in this packaging complies with the prescribed CE safety regulations and UK Conformity Assessment.



Healthbox Go meets the legal requirements for electrical devices.

Belgian General Regulations for Electrical Installations (AREI)

The socket used to connect the unit to the mains voltage must comply with the provisions of the AREI.

2.2 • Safety regulations

PLEASE NOTE

- Ignoring the warnings below may result in malfunction or loss of performance as well as fire, electric shock or injury.
 - A unit that has not been installed in accordance with the installation instructions is not covered by the warranty.
-
- This unit is intended for indoor domestic use. Please contact RENSON® if your situation is different.
 - The Healthbox Go must NOT be placed in areas where the following are present or may occur:
 - Excessively greasy atmosphere
 - Corrosive or flammable gases, liquids or vapours
 - Room air temperatures above 50°C or below -10°C
 - Relative humidity higher than 90% or outdoor installation
 - The unit and associated parts and controls must not be used in places where they may be subject to water jets.
 - All cabling must be installed by a qualified person.
 - Ensure the electrical power supply is equal to single-phase 230 V 50 Hz.
 - When installing, take into account the conformity of noise requirements according to the applicable standard (Belgium: NBN S01-400-1, Section 8).
 - For the extraction of polluted air, extraction of outside air must be provided via the roof (roof ducts) or via the wall (wall ducts). A non-return valve must be included if wall ducts are used.
 - Only appropriate RENSON® accessories and controls can be used with the unit.
 - Modifications to the Healthbox Go are not permitted.
 - The unit cannot be opened without tools. Opening the unit may result in damage to the device or personal injury.
 - Observe national/regional/company regulations when working in confined spaces.
 - Installation of the Renson Healthbox Go must be carried out in accordance with general and locally applicable construction, safety, and installation regulations from municipal/urban and/or other bodies.
 - If the power cable is damaged, it must be replaced by the manufacturer, its service representative or similarly qualified persons in order to avoid a hazard.
 - The Renson Healthbox Go is constructed in a way that makes it impossible to come into contact with moving or live components during normal usage and without performing specific actions.
 - The device must be installed so that it is touch-safe. This means, among other things, that under normal operating conditions no one can reach moving or live parts of the fan unit without taking a conscious action, such as:
 - Dismantling the cover plate.
 - Disconnecting an air duct and/or cover plate on the supply or discharge points during normal use.

PLEASE NOTE

- The ventilation system must function permanently, which means the Healthbox Go must never be switched off (legal obligation according to NBN D50-001).
- The unit is only suitable for use in domestic homes. The unit is not suitable for industrial use, such as in swimming pools or saunas. Installation in an industrial environment may damage the unit.

2.3 • System in operation

- It is the installer's job to inform the user how the unit works and how it can be maintained.
- Only use the product for the applications for which it is designed as stated in the manual.
- Maintenance instructions must be followed precisely to prevent damage and/or wear.
- It is recommended to conclude a maintenance contract.

2.4 • Specific measures

PLEASE NOTE

Ensure Renson Healthbox Go remains easily accessible at all times so maintenance and servicing can be carried out easily.

- RENSON® Healthbox Go meets the legal requirements for electrical devices.
- The fan unit can only be used with appropriate RENSON® accessories.
- Use RENSON® Easyflex air ducts to guarantee air transport according to the best air tightness class D.
- Install RENSON® extraction louvres. This results in lower energy consumption and lower noise production from the fans.
- Install RENSON® Aludec flexible air ducts or Acoudec flexible air ducts with high acoustic damping properties. Install Isodec flexible air ducts with thermal insulating properties.
- Install RENSON® roof and/or wall duct to minimise pressure drops. This results in lower energy consumption and lower noise production from the fans.
- The installer must ensure that the fan unit air exhaust is placed at a sufficient distance from the exhaust and supply of the heating boiler in accordance with the applicable regional regulations.
- It should not be possible to touch the ventilator with your hand. Therefore, Renson Healthbox Go must always have an air duct network connected before use. The minimum duct length is 0.5 m.
- If Renson Healthbox Go is combined with compartmentalisation products to reduce the risk of fire spreading: Ensure the fire damper/butterfly valve/cuff/etc. has sufficient free air passage to limit pressure loss. The incorrect choice of type can lead to poor functioning of the Renson Healthbox Go.

2.5 • Electrical

PLEASE NOTE

- Connect the unit to a 230 VAC 50/60 Hz power supply. Any other power connection will cause damage to the unit.
- The unit must function continuously, i.e. based on the applicable legislation (NBN D50.001), and permanent ventilation must be provided. In order to ensure proper functioning of this sensor-controlled system, the unit must never be switched off.
- Always switch off the power supply to the unit before you start working on the ventilation system. Leaving the unit open while it is operating could result in personal injury. Make sure the unit cannot be switched on accidentally. The unit can be disconnected from the power supply network by removing the power cable from the wall socket or by switching off the fuse. If there is any doubt, check whether this has actually happened.
- If no permanent cabling is provided and the power cable is damaged, it can only be replaced with a power cable from Renson. If this is not respected and different cabling is used, any warranty and/or liability for the poor functioning of the product will be void.

Electronic components

Static electricity can cause damage to electronics.

PLEASE NOTE

When working with electronics, always take protective measures such as wearing a grounded wrist strap.

2.6 • Moving parts

PLEASE NOTE

- Always connect air ducts of at least 500 mm to the unit before connecting the power supply. This means no one can touch the motor when the unit is in operation.

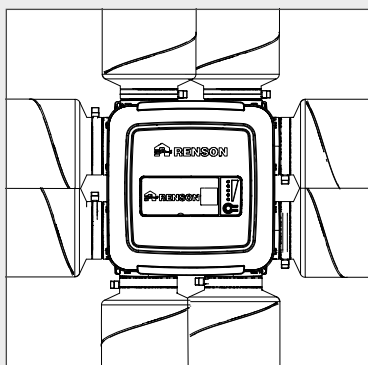

After installation, all components that could cause personal injury are safely contained within the housing. You can only open the housing with tools.

2.7 • Personal Protective Equipment (PPE)

- Wear a helmet and safety shoes when certain parts are lifted or hoisted during installation. It is important that you also wear a helmet if the unit is placed on the ceiling.
- Always wear gloves when handling metal parts such as the fan as they may be sharp!
- Wear an anti-static wrist strap when working on a PCB.

2.8 • Privacy Statement

- When the unit is connected to the internet, the unit automatically sends unit data to Renson.
- For more information about this data processing, see www.renson.eu/privacy or contact us at privacy@renson.be.
- The air quality sensor data is used to display graphs (history) charts for the user.
- As an installer, you are not automatically entitled to inspect the sensor data from a Renson Healthbox Go you have installed, see General Data Protection Regulation (GDPR).
- If a customer's Renson Healthbox Go is connected to your own account via the user app, you have access to the personal data of that customer and you are a data processor within the context of GDPR. In this case, you must comply with the responsibilities of a data processor imposed by privacy legislation. We initially recommend that you unlink your customer's unit from your account (via user app or user web portal) before the customer starts using the home. If you do not do this, you are responsible for complying with the requirements of privacy legislation.

3 • General description of the Renson Healthbox Go unit

3.1 • Operating principle

The RENSON® Healthbox Go is a C+ extraction fan unit. The unit mechanically extracts polluted air from the home by way of the integrated fan. Fresh air is supplied via Renson Invisivent window louvres.

The proper functioning of the Renson Healthbox Go can only be guaranteed if the interior doors of the home have sufficient and correctly dimensioned apertures. A door louvre can be fitted, or the bottom of the door could have a gap with a minimum airflow of 25 m³/h at 2 Pa.

The Renson Healthbox Go is fitted with a sensor PCB with four sensors (RH + TEMP + VOC + CO₂) that measure the interior air drawn in.

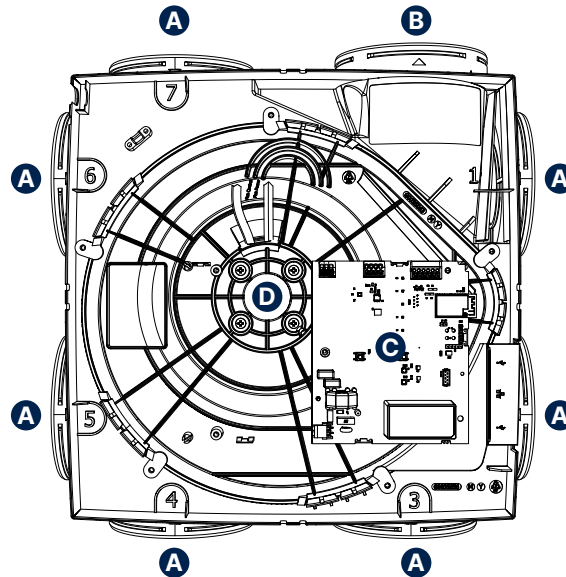
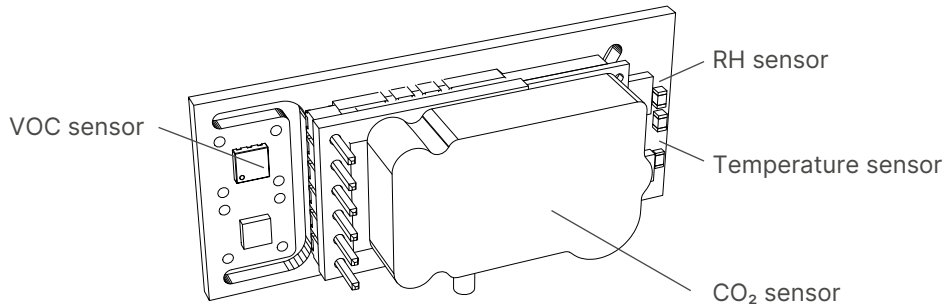

	Certification
A	Extraction of polluted air from the interior
B	Polluted air being extracted to outside
C	Main PCB
D	The fan

3.2 • Installation properties

Healthbox Go can be installed in any direction.

- Upright
- Flat (top/bottom)
- Angled

Installation can be done in 3 ways:

- Wall-mounted
 - Ceiling-mounted
 - Floor-mounted
-
- Connecting the air ducts: 7 connection points
 - Range of matching assortment of ducts.
 - Range also includes roof ducts and wall ducts.
 - Unit behaviour customisable using the Renson Sense app

3.3 • Service properties

Startup via the Sense app:

With the Sense app, the smartphone can be used as a remote for the Healthbox Go settings. What's more, the app offers insight into the unit's proper functioning - it is an intuitive tool for customising the unit's operation.

3.4 • Maintaining air quality

- Excessive CO₂ levels are unhealthy and can lead to concentration problems, as well as health problems such as headaches and a poor night's sleep.
- CO₂ mainly accumulates when many people are present in one room.
- The Renson Healthbox Go is CO₂-driven. The sensor measures the CO₂ content 24/7 and uses intelligent demand management. The big advantage of this is that the sound level within the home is always as low as possible, as is the energy consumption.
- As standard, ventilation continues above the basic level until the CO₂ content has fallen below 950 ppm (this value can be set). By comparison, outdoor air CO₂ levels are between 350 and 450 ppm.
- Excessive moisture content can lead to moisture accumulation or mould formation and health problems such as eye, nose and respiratory problems.
- The ventilation system aims to maintain an acceptable moisture content.
- The central VOC sensor helps the ventilation system to remove sudden odours.

3.5 • Identification

3.5.1 • Identification label

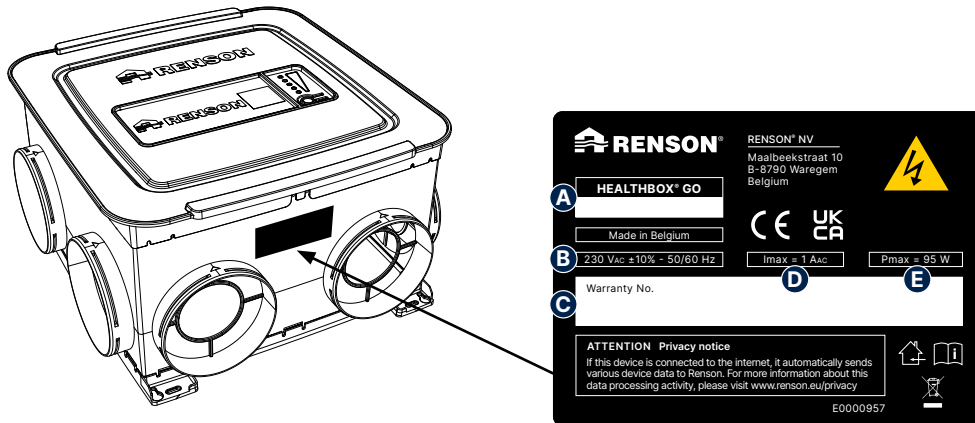

Pos.	Info	Pos.	Info
A	Type, version number and serial number	D	Max. amperage
B	Mains voltage	E	Maximum power consumption
C	Warranty number		

3.5.2 • Information to be provided when contacting RENSON®

Always provide the warranty number when you contact RENSON®, or when requesting service for your unit. Always report any complaints to the installer first. If necessary, the installer will contact the RENSON® service department.

3.6 • Warranty terms and conditions

- The warranty period for the customer is 2 years from the date of production. The unit is deemed to have been installed no later than 1 year after the date of manufacture.
- All pipes must be supported and mounted according to best practise. If any actions other than those mentioned are carried out, RENSON® is not responsible and the warranty will be void.
- Only appropriate RENSON® accessories and controls can be used with the unit.
- Modifications to the Healthbox Go are not permitted.

INSTALLER

4 • Material

4.1 • Disposing of the device

Old electrical and electronic units often contain valuable materials. However, they also contain harmful substances that are necessary for the functioning and safety of the unit. Never dispose of the discarded unit with normal waste.



Dispose of the unit in an environmentally-friendly manner by taking it to the appropriate collection point.

5 • Ventilation unit description

5.1 • Checking the delivery

Contact the supplier immediately if damage is found when opening the packaging or if it appears that the delivery is incomplete.

Each packaged kit (32753) contains the following components:

A	1 x Healthbox Go	E	Quick start guide
B	Power cable 2m	F	3 x Aeroo valve
C	3 x Adaptor Ø 125 mm	G	3 x tie-wrap
D	6 x cap		

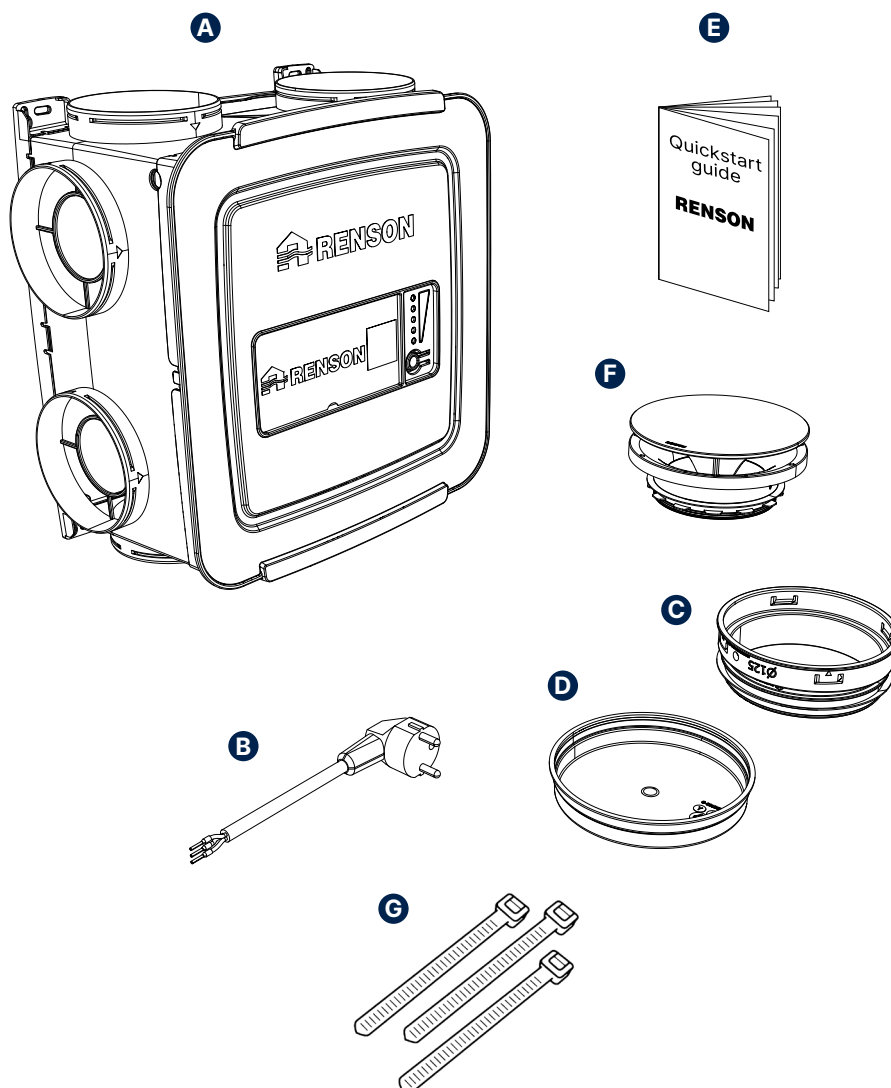

5.2 • General description

Healthbox Go is a mechanical extraction unit compliant with a C+ ventilation system. The fan extracts polluted air. Fresh air is supplied to the home via Invisivent window louvres into the dry rooms. As the Healthbox Go is sensor-controlled, there is neither too much nor too little ventilation. This compact & flexible ventilation unit is suitable for residential applications with a nominal ventilation demand of up to 430m³/h.

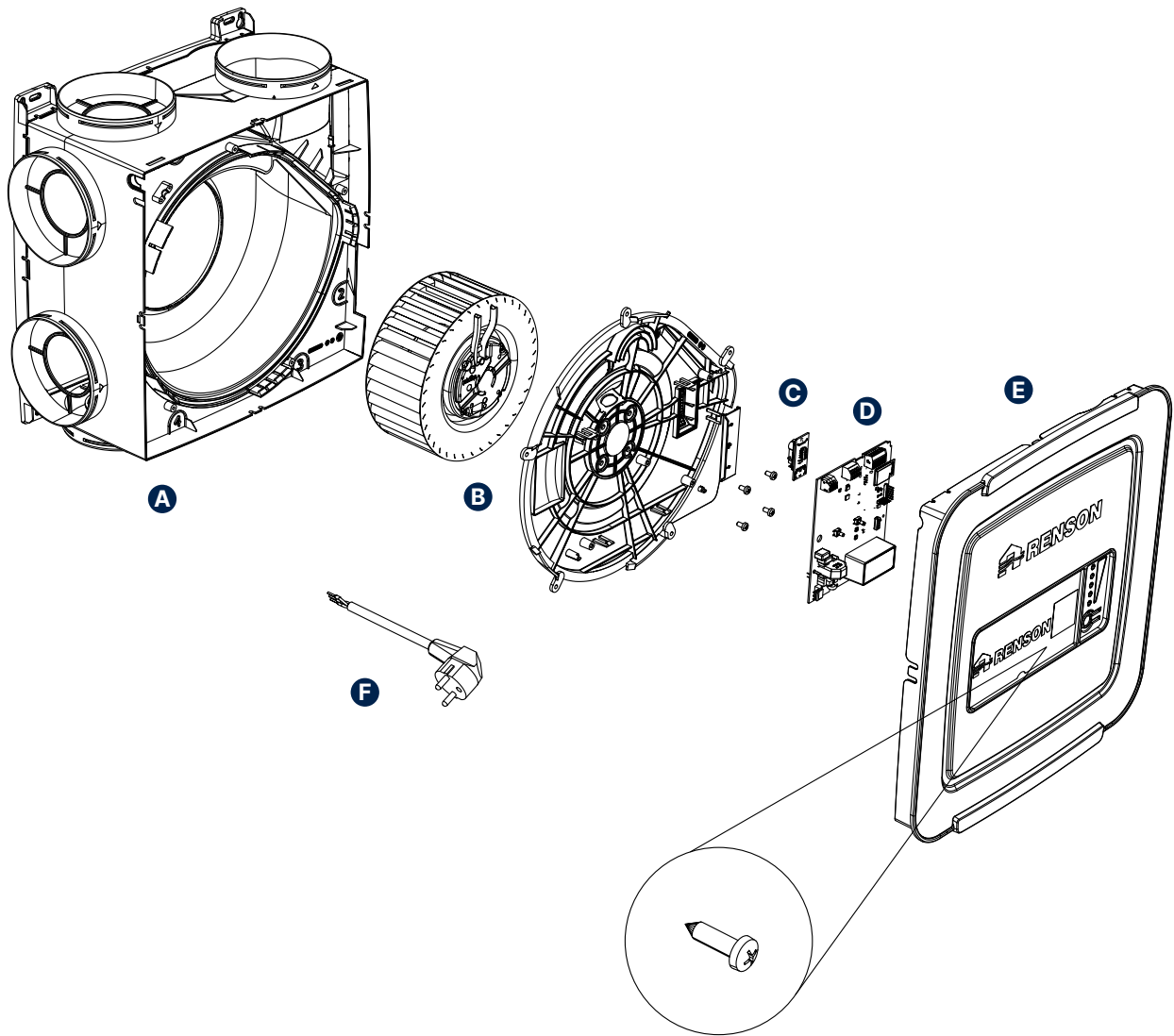

Pos.	Part	Number Spare Part	Quantity	Function
A	Housing		1	
B	Fan with cover		1	
C	Sensor PCB		1	CO ₂ + RH + VOC detection
D	Main PCB		1	
E	Cover		1	
F	Power cable		1	

5.3 • Technical specifications

5.3.1 • Technical specifications

Type of ventilation	Mechanical demand-driven extraction
Ventilation flow rate	Total flow rate of 430 m ³ /h at maximum pressure of 200 Pa
Connection voltage	230 Vac ±10% (50 Hz, 60 Hz)
Fan unit power consumption - At max. flow rate 150 m ³ /h: - At max. flow rate 225 m ³ /h: - At max. flow rate 325 m ³ /h: - At max. flow rate 400 m ³ /h: - At max. flow rate 475 m ³ /h:	28 watts 35 watts 53 watts 80 watts 85 watts Power curves: see 'Graphs' section
Dimensions	390 × 390 × 220 mm (L x W x H)
Weight: - Ventilator unit without control modules	3992 g
Ø connection per supply duct	Ø 125 mm
Ø connection per extraction duct	Outlet point Ø 125 mm (option: adaptor to Ø 150 mm)
Fan	Extremely quiet & energy-efficient EC motor - Thermally protected - 0-10 V powered
Sound output level (LWA) <i>(Ecodesign-compliant reference point)</i>	Qmax 150 m ³ /h: 32 DB(A) Qmax 225 m ³ /h: 34 DB(A) Qmax 325 m ³ /h: 39 DB(A) Qmax 400 m ³ /h: 43 DB(A) Qmax 475 m ³ /h: 47 dB(A)
Material use	Recyclable UPVC housing (polypropylene)
Breeze function	Temporary nominal ventilation (= deactivation of demand-driven control) at times when a certain level of cooling is required (⇒ optimal reduction factors)

5.3.2 • Control of demand-driven ventilation

Demand-driven ventilation: air quality detection (CO ₂ , moisture and VOC)	Via electronic sensors in the unit. The sensors measure the indoor air quality in the extracted air flow for each room, 24 hrs per day.
Operation options	- Demand-driven (Standard) - Manual control (User app) - Timers (User app) - Repetitive schedule (User app)

5.3.3 • Control

Resident's app:

- Read the air quality in the home
- Personalisation and (temporary) manual adjustment of the ventilation air flow rate possible

Optional:

- Potential-free wired 3-way switch for manual adjustment of the ventilation extraction air flow rate (see Chapter 8.3)

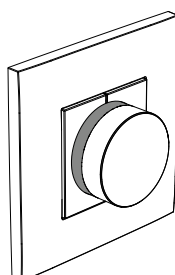

5.3.4 • Installation

Installer app (Sense app)	Quick adjustment
---------------------------	------------------

Installation

Room	Indoor installation, preferably in an insulated space. Temperature limits from -10 °C to +50 °C.
Installation options	Can be installed in all directions: horizontally, vertically, etc.
Exhaust and supply in the central extraction duct of an apartment building	✓

5.3.5 • Compatible products

Extraction valves	Design adjustable extraction valve (built-in or recessed) and Aeroo valves
Easyflex air ducts	Air transport ducts, best airtightness class D
Acoudec	Air flexible duct with high acoustic damping properties
Roof duct / wall duct	Suitable ducts with limited pressure loss. For wall duct, combine with a non-return valve.

5.3.6 • Additional features

Automatic fault indication	Via the SENSE app
Automatic software updates	Provided that the Healthbox Go is connected to the internet
Sense app	Can be downloaded free of charge from Play Store (Android) and App Store (Apple) – Renson applications
Integration in smart home & home automation	Smart home: via API Domotics: switching module (3 contacts)
External input/output contacts	3-way switch (minimum and boost modes)
Fire safety	Fireproof housing
EU declaration of conformity	✓
Energy performance regulation (EPB)	– Reduction factors conforming to Table 2 of the flat-rate table – Included in EPB product data base – FAN AND VENTILATION GROUP – Included in EPB product data database – DEMAND-DRIVEN VENTILATION SYSTEMS

Consult our website www.renson.net (products → mechanical ventilation) for more information.



5.3.7 • Graphs

Ventilation characteristics of fan unit

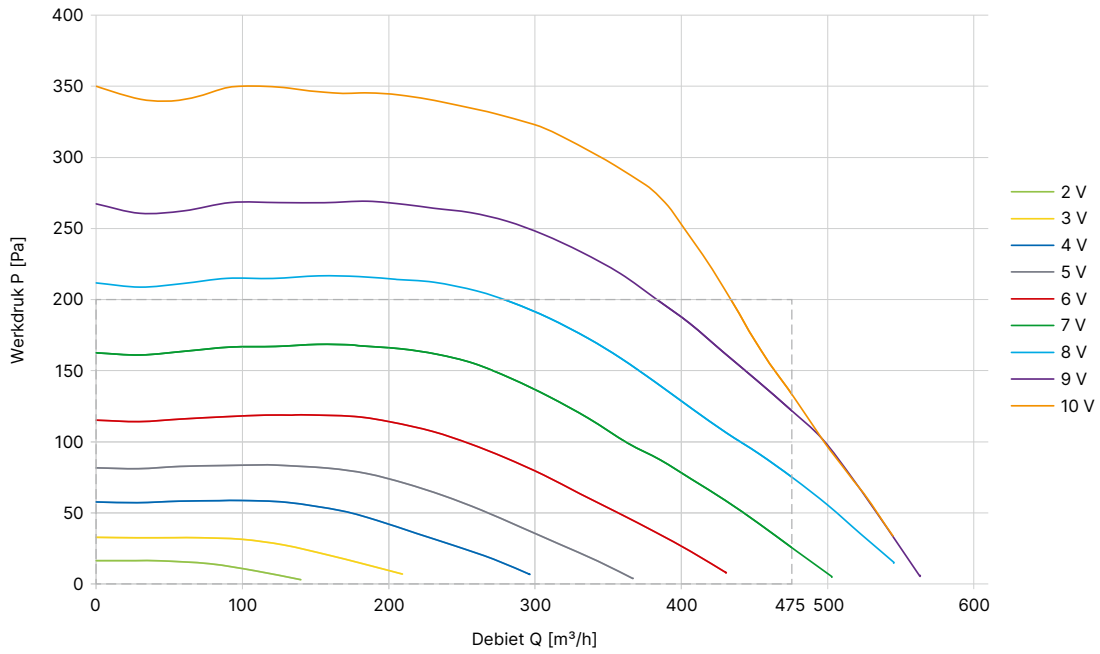

Power curves fan

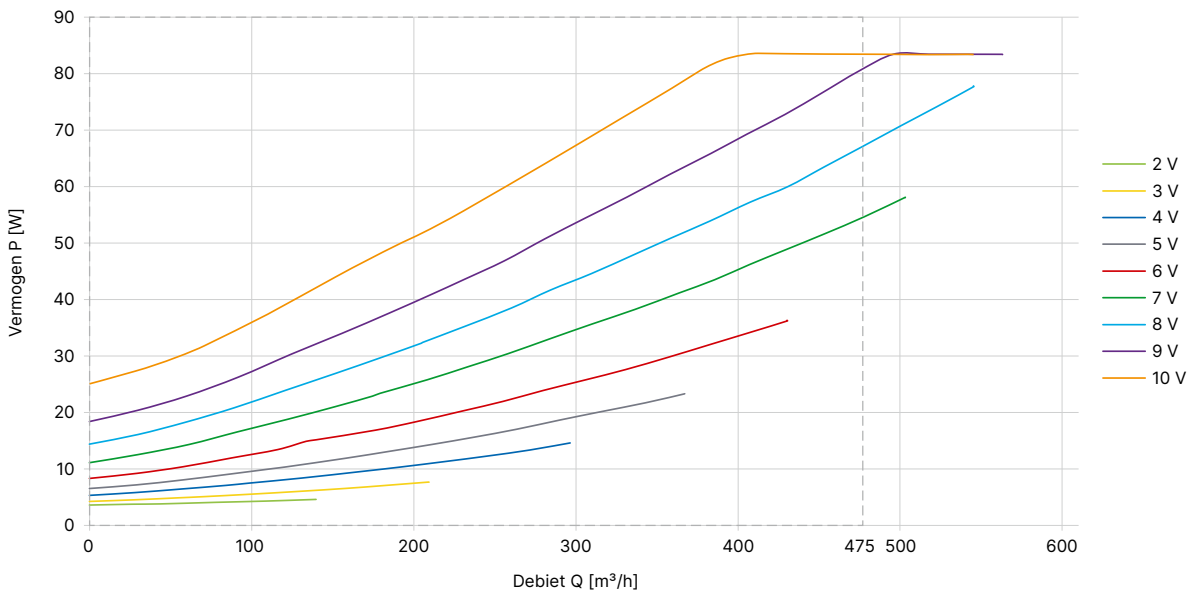

INSTALLER

5.3.8 • Dimensions and weight

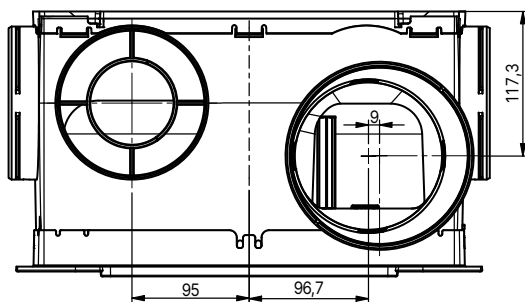
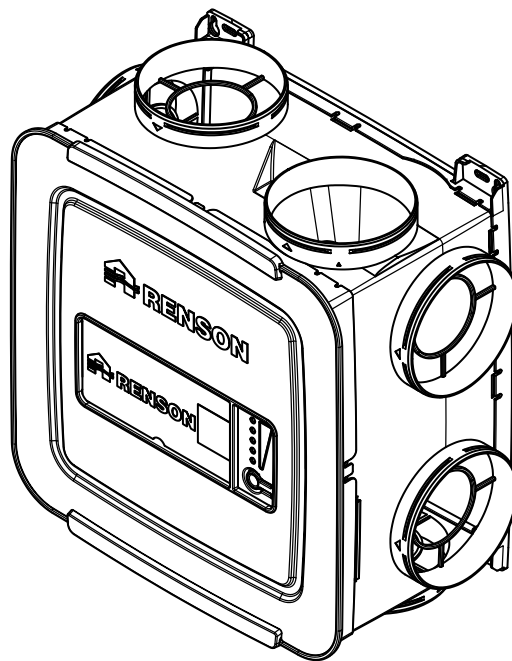
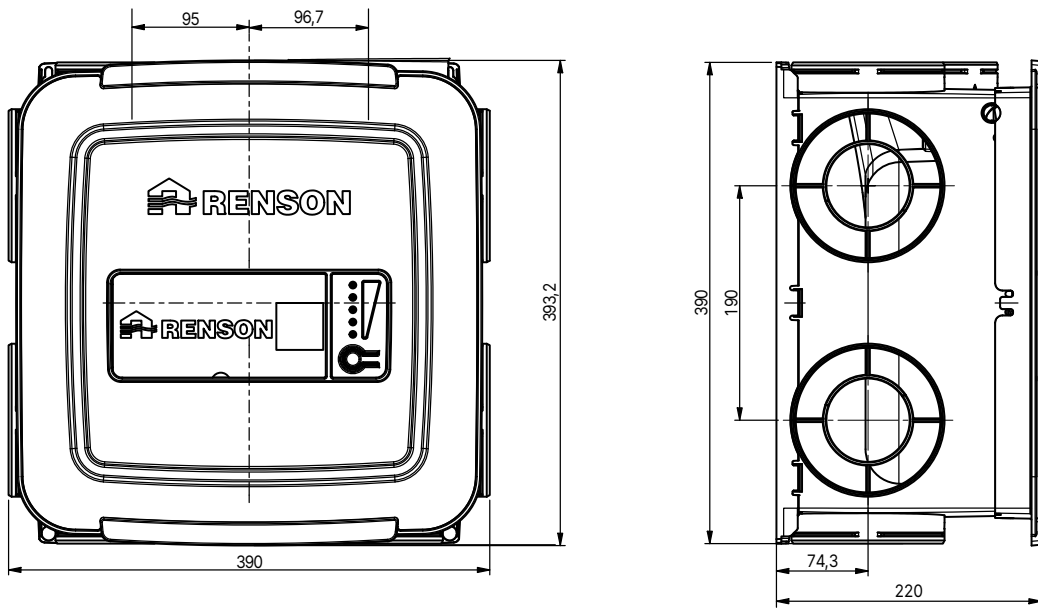

INSTALLER

5.4 • General installation conditions

Read the safety and installation conditions carefully.

- Select the installation area in the technical room, loft or elsewhere (near the roof or wall ducts). Position the unit in a central location in relation to the rooms to be ventilated so that the duct lengths are distributed as homogeneously as possible and resistance across the duct network is limited. To limit possible noise transmission, do not place the unit above or in a bedroom.
- Ensure there is sufficient space around the unit to connect the ventilation ducts without issue, and to carry out inspection and maintenance. Avoid obstacles that prevent access or removal of the unit.
- The Healthbox Go must **not** be connected an extractor hood or dryer.
- The unit's extraction should always be to outside

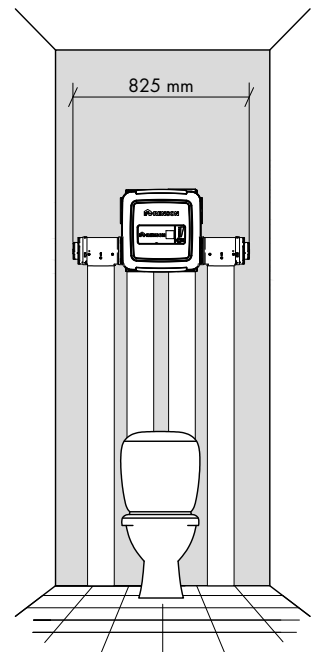

6 • Installation

6.1 • Preparing the unit for installation

6.1.1 • Tools

- Drill
- Electric screwdriver with bits
- Stanley knife
- Pliers
- Pencil, marker for marking

6.2 • Mounting the unit

Healthbox Go can be fixed to a wall/ceiling/floor with 4 suitable screws for the respective surface using the integrated mounting holes.

Ensure the surface is flat.

Preferably ensure vibration-free installation to a solid wall/ceiling with a minimum mass of 100 kg/m². It is recommended to use vibration-damping material between the fan unit and the installation wall.

If necessary, install the roof duct/wall duct if not already in place.

Use the drilling template included in the kit (item 32753) with the 3 Aeroo valves.

The Healthbox 3.0 template can also be used if you only purchased the ventilation unit. Use the template to mark the position of the drillholes for the wall plugs.

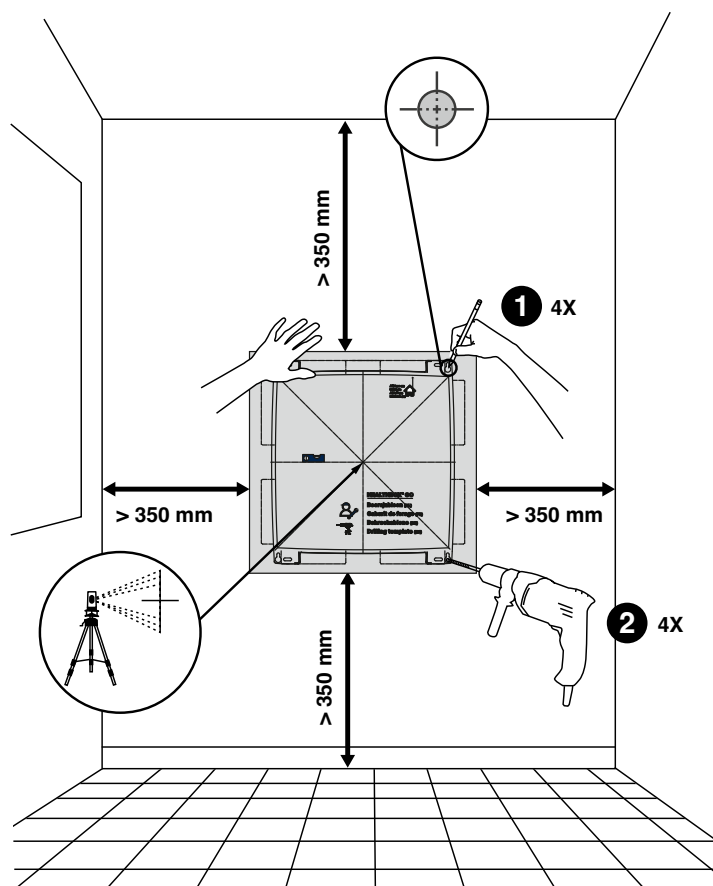

The drill holes can also be positioned by marking the dimensions indicated here directly onto the surface.

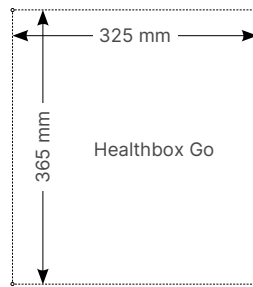

Fix wall plugs and screws (suitable for the surface type). Ensure that the screw heads protrude approximately 4 mm from the wall as shown in the figure. If a threaded rod is used, make sure there is a nut on the end.

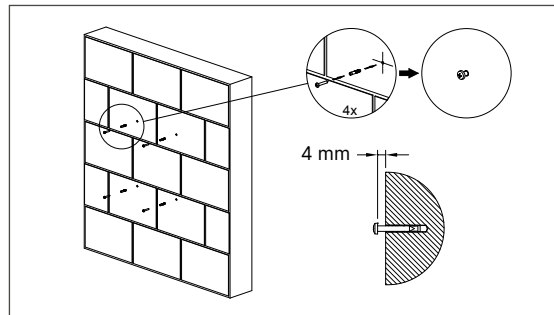

Hook the fan unit over the 4 pre-mounted screws.

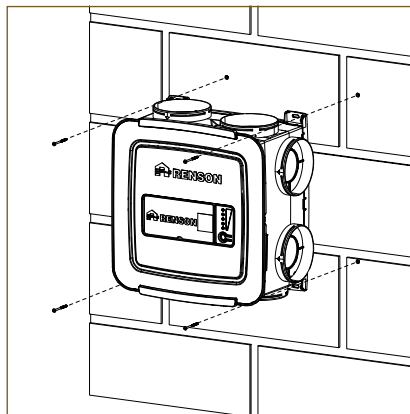

6.3 • Installing air ducts

- Secure the fixed air ducts so that the Healthbox Go is not weighed down by the weight of the air ducts.
- Ensure the air duct network is airtight. The Renson Easyflex pipes meet the best air-tightness class, D.
- Avoid the use of sharp angles (<math><90^\circ</math>) as much as possible, both in fixed air ducts as in flexible piping.
- Avoid sharp angles in the pipes very near the Renson Healthbox Go.
- For risers, round air ducts are recommended.
- To prevent condensation forming in the air ducts, use insulated air ducts/pipes if located outside of the insulated space of the home.
- Use fixed air ducts as much wherever possible. There is less air resistance with fixed air ducts than with aluminium flexible ducts (like Aludec, Acoudec and Isodec), and their purpose is to bridge distance.
- The purpose of the aluminium flexible ducts is to provide a gradual curve and dampen vibrations.
- Ensure the ducts are easily accessible for cleaning.

- The dimensions of the required extraction ducts are dependent on the intended extraction flow rates.
- In addition to choosing high-quality components, correct installation is also essential for a well-functioning ventilation system. Correctly dimensioning the piping system plays an important role in this. Correct sizing of the pipe system significantly reduces fan consumption and improves acoustic comfort. The table below provides an overview of the maximum recommended air flow rates through the Renson pipe components. Please note that this table does not address pressure drops. To limit the pressure drop across the channels, the length and especially the number of bends per channel must also be limited. If in doubt, contact your contact person at “Renson Engineering” if you wish to receive personalised advice and a plan.

https://www.renson.eu/Renson/media/Renson-documents/BENG/renson_leidingsysteem/Tabel1_Dimensioneringstabel_Renson_leidingsysteem_NL.pdf



If using RENSON® Easyflex air ducts:

Air flow rate	Air duct(s)
≤ 50 m ³ /h	1 air duct (at air velocity of 2.5 m/s)
≥ 50 m ³ /h	2 air ducts (at air velocity of 2.5 m/s)
≤ 50 m ³ /h	Ø 80 mm or equivalent
> 50 m ³ /h	Ø 125 mm or equivalent

Acoustics

- Certain situation may require the use of acoustic damping material (bedrooms, open kitchen, etc.).
- We strongly recommend installing a sound absorber (Acoudec) if the supply pipes between the extraction point and the fan unit are shorter than 3 metres to prevent any noise nuisance.
- If the air duct between the extraction point and the fan unit is shorter than 1 metre, installing a sound absorber (Acoudec) is mandatory.
- We always strongly recommend installing a sound absorber (Acoudec) to limit noise nuisance if using spiral ducts.
- Always install the sound absorber as close to the unit as possible.
- For additional sound absorption, acoustic damping material can also be installed in a downward angle from the extraction louvre. However, please ensure the predetermined flow rate is still achieved.



TIP

Renson recommends always installing 1 m of Acoudec acoustic damping material. Together with respecting the correct ducting rules to obtain an acceptable pressure drop, this ensures quiet operation of the ventilation system. Always place the sound absorber as close as possible to the fan unit.

6.4 • Installing extraction valves

Carefully select the location (In ceiling or wall) for the extraction louvre.

The idea is to position the extraction louvre as far away as possible from the supply opening as possible, so that the room is fully flushed.

We recommend using diameter 125 for the extraction valve. The Aeroo valve is a very good choice for this purpose. This valve is easy to adjust and clean, and is extremely quiet.



In some cases, it might be interesting to use a valve with a diameter of 80 mm. For example, if the space for a pipe is very limited during renovation and only a diameter of 80 mm is possible. However, do this only for low flow rates, such as a toilet (25 m³/h).

Here, you could use the Design extraction louvre range, also available in 80 mm diameter.

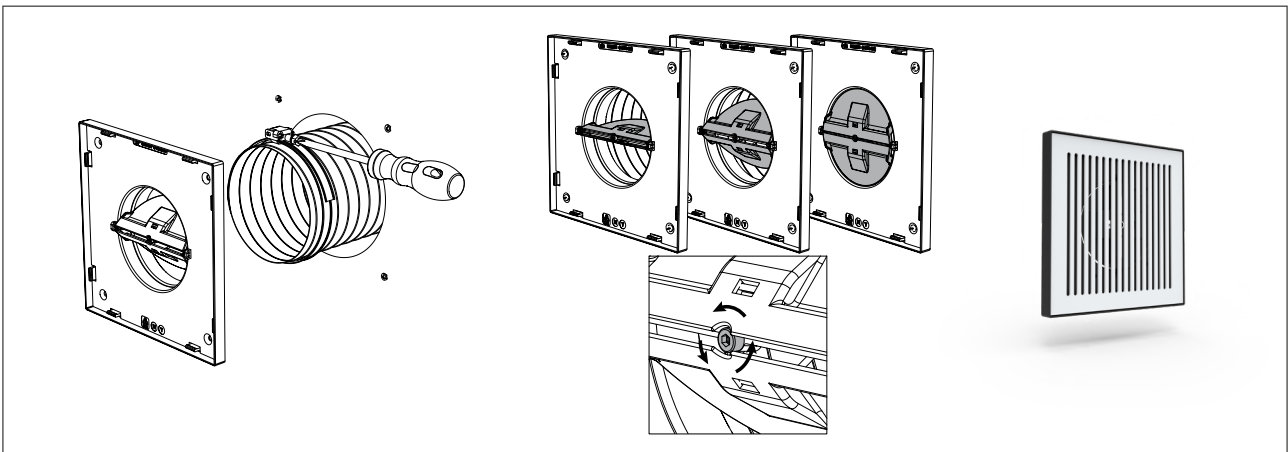

6.5 • Extraction of polluted air to outside

The extraction of polluted air must occur via the roof (roof ducts) or via the wall (wall ducts).

A non-return valve must be installed if using a wall duct. This could be either a wall duct louvre with integrated non-return valve (Type 641) or a separate non-return valve in the pipe.

When designing a ventilation system, it is essential to select the correct diameter for the outlet pipe to ensure efficient air flow. For smaller volumes, such as a total of up to 177m³/h, a Ø125 mm pipe is sufficient.

Example:

- Bathroom + toilet: 50 m³/h
- Toilet: 25 m³/h
- Kitchen: 75 m³/h

However, for larger volumes, a larger diameter of Ø150 mm is recommended to increase the system's capacity and reduce air resistance.

Reducer 33098 is a practical solution for bridging the transition from Ø125mm to Ø150 mm.

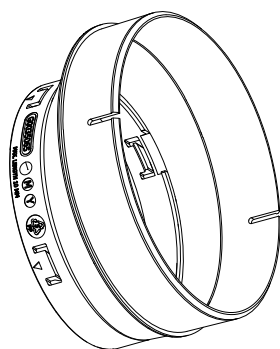

6.6 • Connecting pipes to Healthbox Go

The Healthbox Go kit with Aeroo valves includes 3 adaptor rings. These rings can also be bought separately (Art.nr. 33761).

The adaptor ring is ideal for quick and airtight connection of all types of pipes to the unit.

- Easyflex pipe Ø125 mm
- Acoudec Ø125 mm
- Isodec Ø125 mm

Insert the pipe over the rubber up to the flange. If using a flexible pipe, use a strap so that the flexible pipe is attached to the ring.

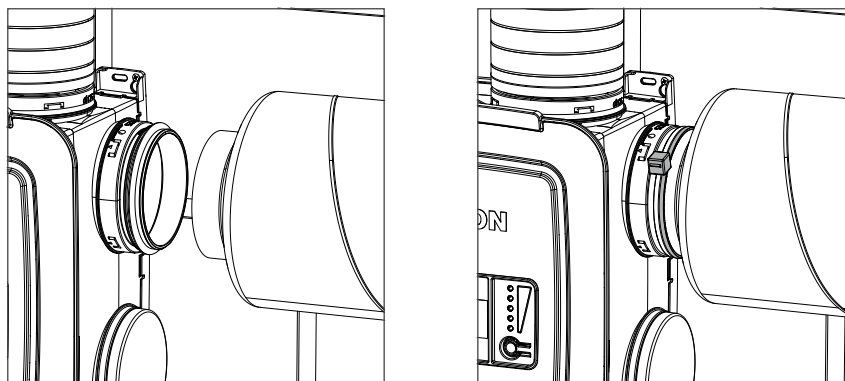

6.7 • Connecting the Healthbox Go

6.7.1 • Healthbox Go PCB

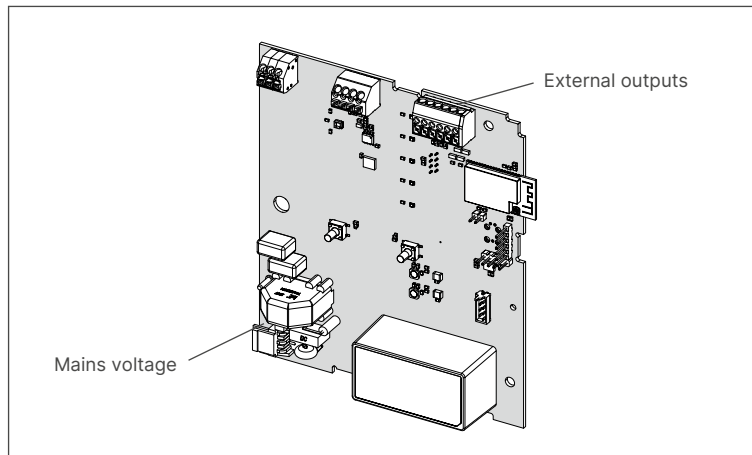

- Mains voltage: connect to the power socket or directly to the fuse box.

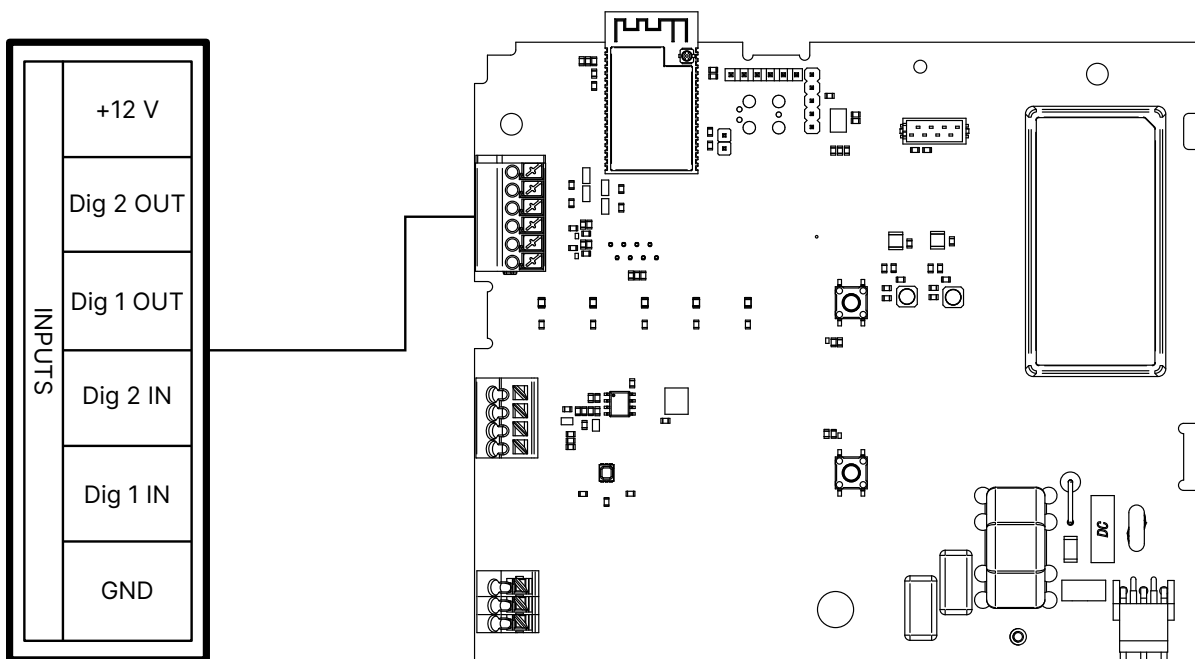

INSTALLER

6.7.2 • Connecting to mains voltage

Healthbox Go can be connected in 2 ways:

- Plug the power cable supplied into the power socket
- Connect directly to the fuse box.

The wires of the cable should be stripped 6 mm before they are connected to the connector.

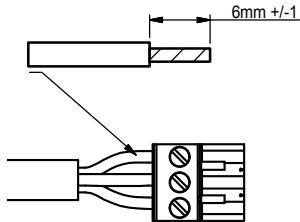

The PCB shows where to connect the L, N, and PE wires.

! PLEASE NOTE

If Healthbox Go is connected directly to the fuse box, the latter must be fitted with a device that can disconnect the Healthbox Go from the power supply network.

This device must be double-poled, must be directly connected to Healthbox Go and must be able to withstand category III surge voltages.

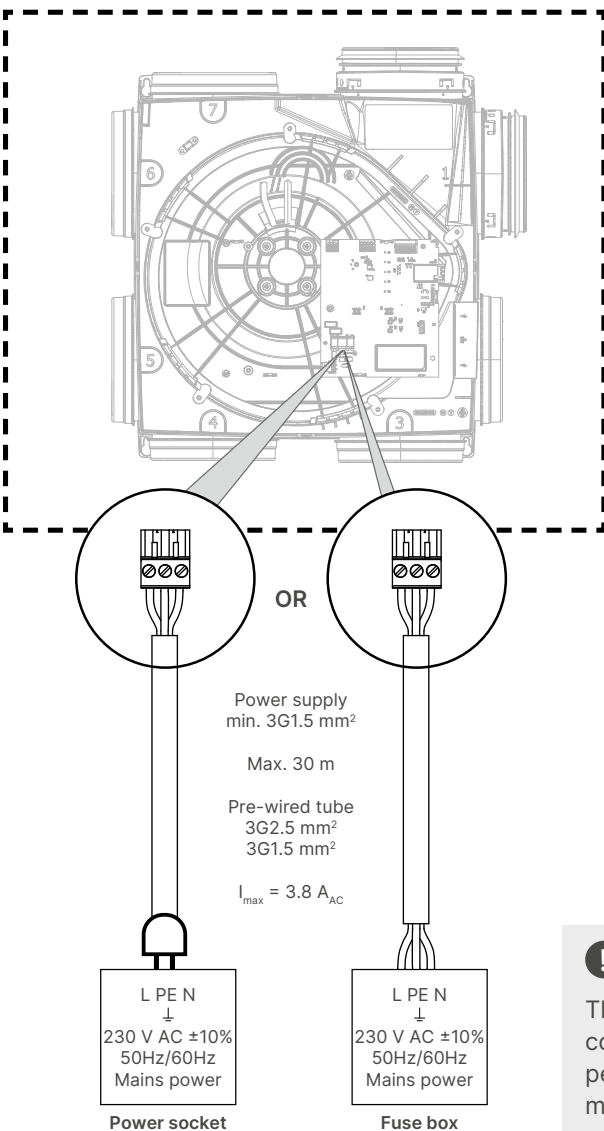

! PLEASE NOTE

The installation and electrical connection of the various components may only be carried out by authorised personnel in accordance with the applicable safety measures.

6.7.3 • Connecting 3-way switch (XVK3)

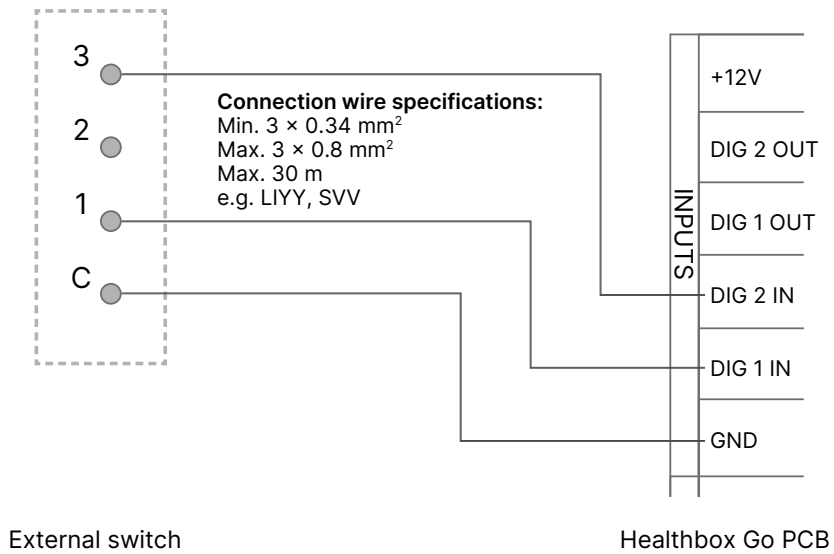

The functionality of the inputs is fixed and defined as follows:

Closed contact or logically HIGH at the input	Healthbox Go operation
1 Dig	Minimum mode: - Demand control inactive - Ventilation level = minimum as set
2 Dig	Boost mode: - Demand control inactive - Value is taken from the intense profile, this is 120% of the nominal flow rate as set.

Healthbox Go will always return to its standard demand-driven operation after a period of 12 hours.

The Healthbox Go operates in standard demand-driven mode if no adjustment is made to the inlet.

INSTALLER

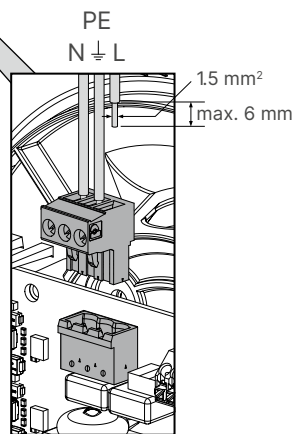
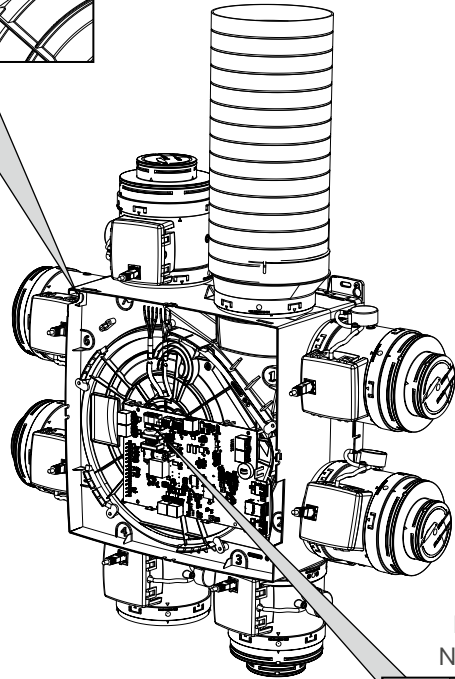
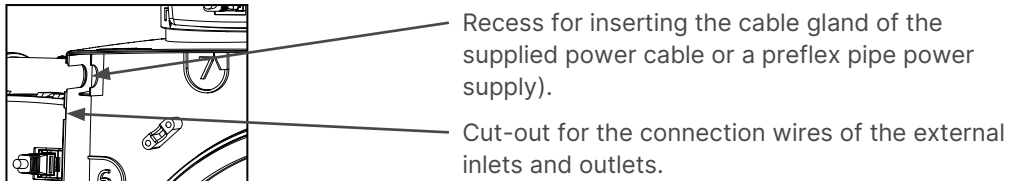

Connecting the power supply

7 • Starting up the Healthbox Go

7.1 • What to do before adjusting the settings

Extreme weather conditions, strong winds for example, can affect the operation of the system. Avoid adjusting the Healthbox Go in these circumstances.



TIP

Before starting automatic calibration, it is important that:

1. All window vents are fully opened
2. All windows are closed
3. Interior doors are closed (preferably)
4. Switch off all other installations that bring outside air in or send indoor air out.

- Ensure that the main voltage is switched (back) on.

Start-up check: the Healthbox Go operating system is booted up, the LEDs show a wave pattern for 10 seconds. This shows there is effective voltage on the unit. After this, all LEDs will turn off.

The unit is now running demand-driven in its factory settings (60% of the maximum flow rate).

In practice, this flow rate has proven to be a good starting point for adjusting the settings.

You can adjust the flow rate either via the unit and the push buttons or via the app.

7.1.1 • Settings using the push buttons

Removing the booklet from the cover gives you access to:

- The installer button
- Cover screw
- LED mode

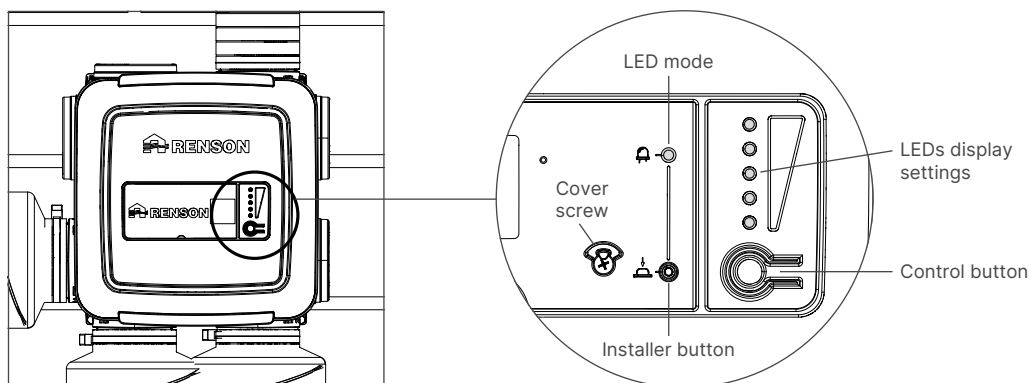

Press the installer button, e.g. with a screwdriver, to scroll through the sequence of different menus. The colour of the LED mode indicates which menu you are in. After pressing 4 times, the LED will turn off again and you are out of the installer menu.

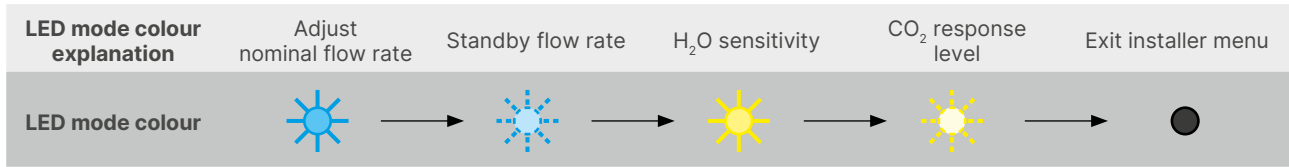

Nominal flow rate	The ventilator's maximum air flow for demand-driven operation as set is intended to achieve the government-mandated air flow rate in each room, distributed over the connected valves.
Standby flow rate	Adjusting the standby flow rate: if the sensors do not pick up a stimulus at demand control, the fan unit will maintain this flow rate to be able to snuffle the air and, if necessary, ramp up to nominal flow rate.
H ₂ O sensitivity	This determines how the unit should respond to moisture. For example, if only 1 room is connected to the unit, percentage-wise the level of moisture in the mixed air will be completely different from having 5 rooms connected with 1 shower room.
CO ₂ response level	You can adjust the unit to your preferences by setting it to keep the CO ₂ level low, or by allowing the level to go up.

INSTALLER

7.1.2 • Adjusting the nominal flow rate using the buttons

Press the installer button once.

The installer LED will show a constant blue light.

The unit will operate on the nominal flow rate for 60 minutes.

This allows the flow rates to be measured at leisure.

The row of LEDs will display the current flow rate as set. If you want to adjust this flow rate, you can do so by pressing the large control button. Each press of the button increases the flow rate by one level. If you want to reduce the flow rate, press the button 9 times.

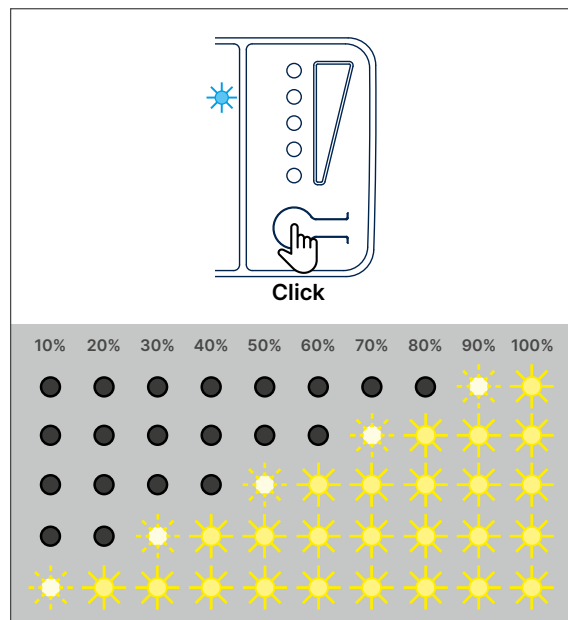

7.1.3 • Adjusting the standby flow rate using the buttons

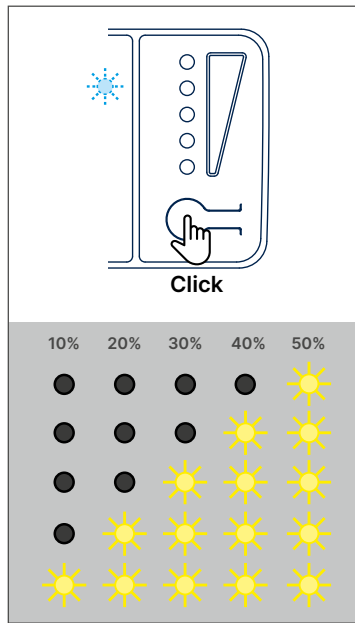

Press the installer button twice so that a blue light flashes on the installer LED. The unit is now in the menu where you can adjust the standby flow rate.

Press the installer button to adjust the minimum flow rate. The standby flow rate is a percentage of the nominal flow rate as set. The unit will immediately move to its minimum as set to give an impression of its noise level.

The unit will automatically exit the installer menus after 15 minutes without input. You can also exit the installer menu by pressing the installer button a number of times until the LED mode no longer lights up.

7.1.4 • Adjusting the humidity sensitivity using the buttons

Depending on the number of connected rooms, the moisture content will be different in the mixed air, for example a shower in one humid room.

As such, it may be necessary to adjust the unit's sensitivity.

Press the installer button until the LED shows a constant yellow light.

Set the humidity sensitivity by pressing the large control button. The unit will exit the installer menu automatically after 10 seconds without input.

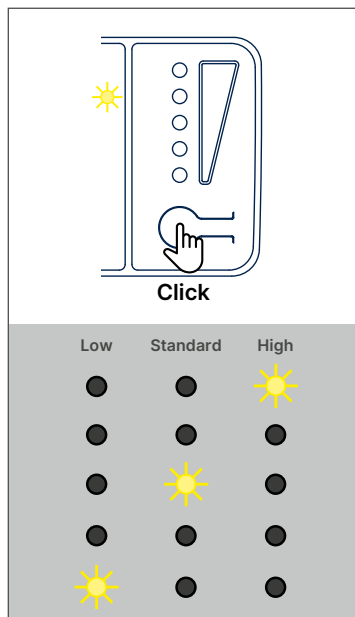

7.1.5 • Adjusting the CO₂ threshold

The response speed to CO₂ can be set depending on the residents' wishes. The unit will exit the installer menu automatically after 10 seconds without input.

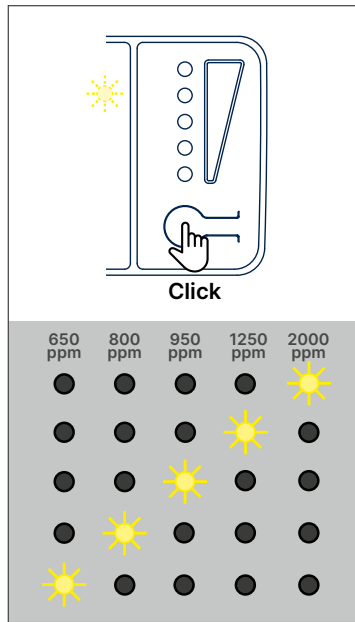

7.1.6 • Adjusting the nominal flow rate using the app

When you plug in the Healthbox Go, the device will automatically create a local Wi-Fi network that remains active for 40 minutes. This will allow you to connect your smartphone to the Healthbox Go, even if there is no internet connection at the construction site.

To restart the network, press and hold the large control button for 5 seconds. The purple installation LED will start flashing, as well as the middle LED in the LED module.

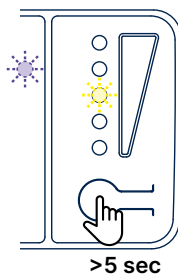

For any other actions, please use the large button. The network will remain active for another 40 minutes.

An iOS or Android phone and a free Sense account are needed to adjust Healthbox Go via the app.

Download the "Sense" app in the Apple App Store or in Google Play and create a free account.

The Healthbox Go "Sense" app will guide you through the configuration process. During this configuration process, Healthbox Go is connected to the internet and all parameters can be set.



After you install the app, you can create an account.

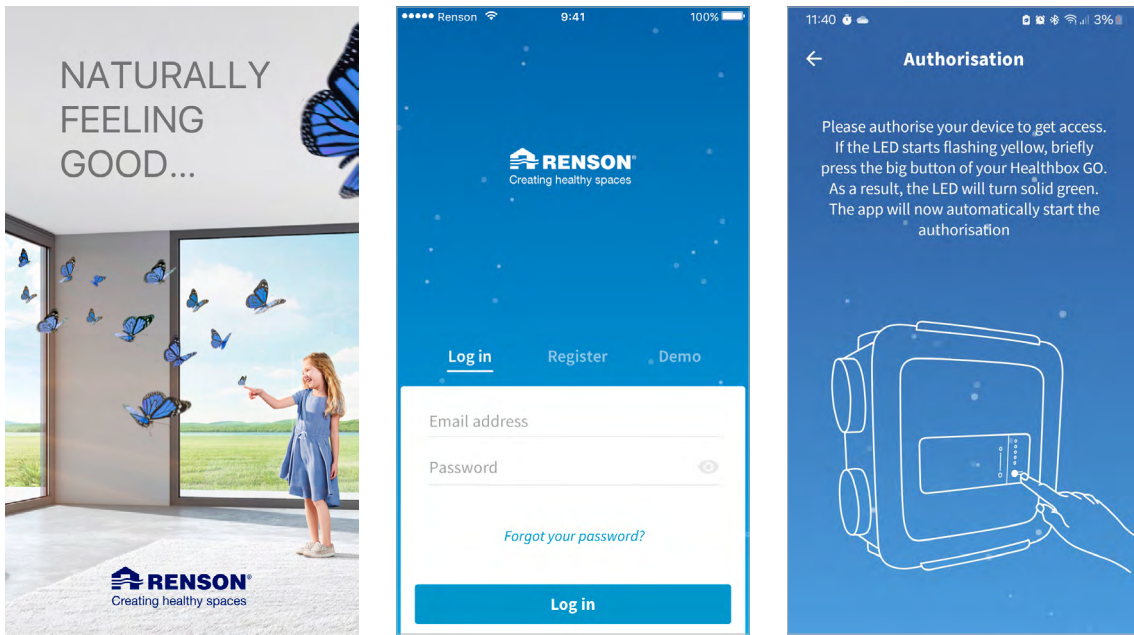

INSTALLER

After setting several parameters, you can adjust the flow rate via the app. This way, the smartphone with Sense app can be used as a remote control for adjusting the valves.

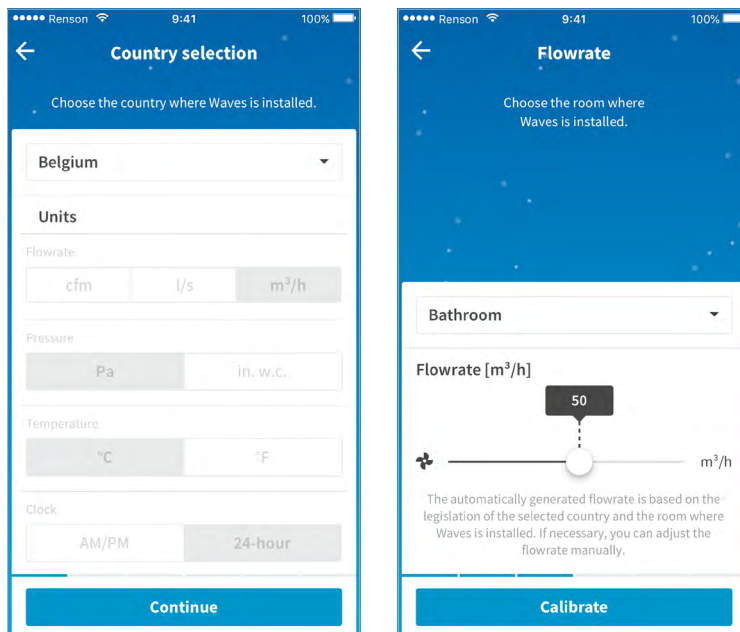

7.2 • Valve settings

- Ensure the unit delivers its nominal flow rate by pressing the large control button. The unit will ramp up to the nominal flow rate as set.
- Ensure that all valves are opened all the way.
- Go to the valve with the highest flow rate and the highest resistance (most bends and furthest away). In many cases, this will be the kitchen.
 - Measure the flow rate here.
 - If the flow rate is too high, reduce the total nominal flow rate of the Healthbox Go
 - If the flow rate is much too low, you can increase the flow rate of the Healthbox Go somewhat right away, if it is only a little too low, continue adjusting the valves. After all, inhibiting the other valves will allow more air to reach the furthest valve and the flow rate will increase anyway.
- Now, check all valves and adjust them.
 - Since the duct system works like communicating vessels, by adjusting the flow rate in one valve, the flow rate of the other valves will also be affected.

7.3 • Controlling the set flow rates

Pressing the large control button will switch the unit to nominal flow rate. The more presses, the more LEDs light up, the longer the unit will run at nominal flow rate.

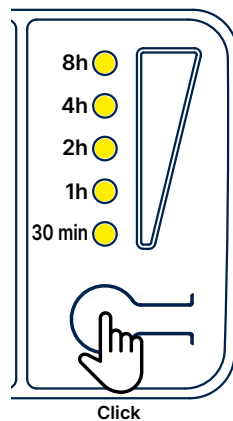

Measure the flow rate at the valves

The unit will automatically return to demand control as soon as the set time has elapsed. The unit can also be switched to demand control manually by pressing the large control button until no LEDs are lit.

7.4 • Resetting the Healthbox Go

To reset Healthbox Go to factory settings, press and hold the installer button for 10 seconds, e.g. with a screwdriver, until the installer LED shows a red light. Release the button. The installer LED will turn green immediately, in the LED row, the bottom LED will show a yellow light.

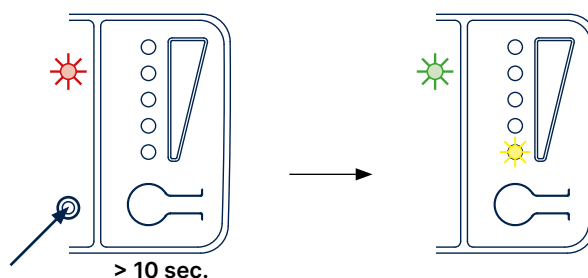

USER

8 • Using the Healthbox Go

Healthbox Go operates autonomously based on the measurement results of the 3 built-in sensors:

- CO₂
- RH or relative humidity
- VOC: detects sudden odours

So basically, manual intervention is not needed.

If you do want more control over the ventilation unit, this is perfectly possible via:

- The Sense app
- The XVK3 switch
- A boost by way of the controls on the Healthbox GO unit itself

8.1 • Using the Sense app

If required, the handy Sense app can be used to boost the system or to customise the functioning of the unit.

Step 1: download the Sense app

You need Wi-Fi, an iOS or Android phone, and a free Sense account to adjust the Healthbox Go via the app.

Download the “Sense” app in the Apple App Store or in Google Play and create a free account.

After you install the app, you can create an account.



Step 2: Link the Sense app to the Healthbox Go

To open the local network of the Healthbox Go so that the Sense app can connect to the Healthbox Go:

Press and hold the large control button for 5 seconds. The purple installation LED will start flashing, as well as the middle LED in the LED module. The local network will be enabled for 40 minutes.

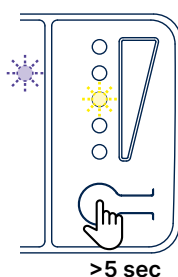

Follow the instructions in the app to link the app with Healthbox Go.

Open the Sense app and add the Healthbox Go as a device.

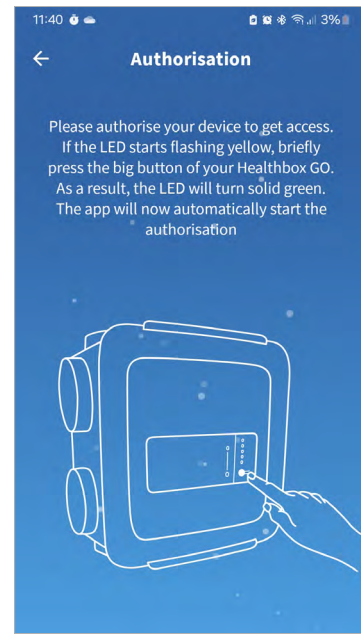
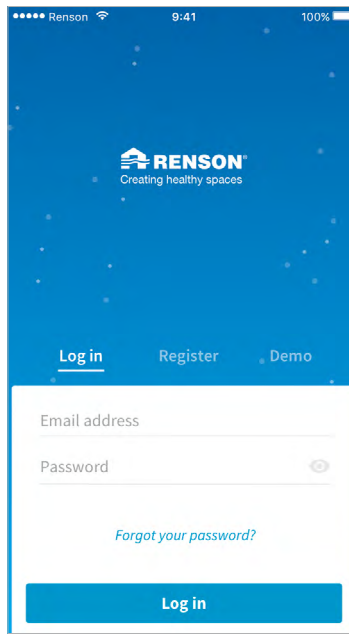
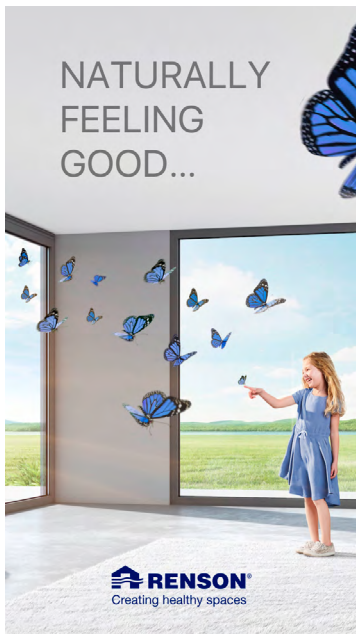

USER

Can then connect Healthbox Go to your home network. This will allow you to monitor the air quality when you are not at home. What's more, software updates can be installed automatically.

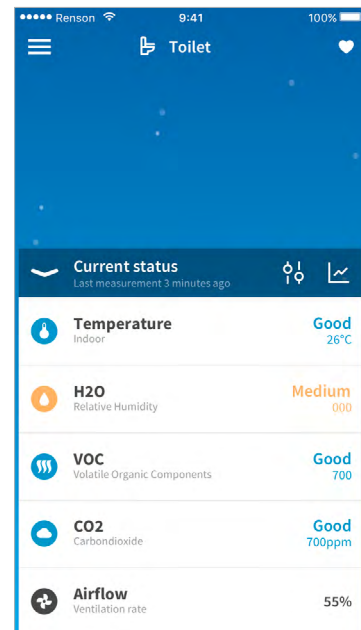
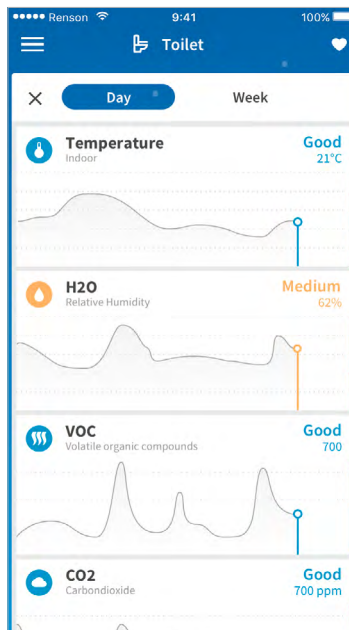
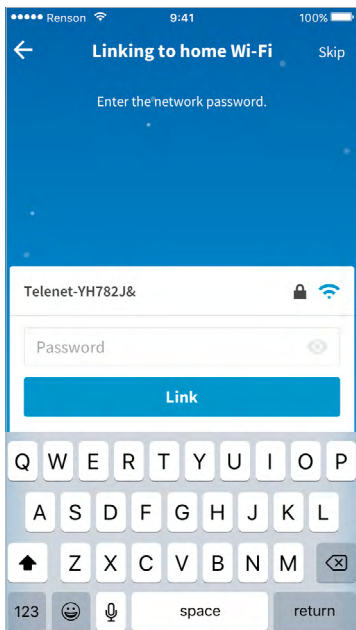

Step 3: Customise how the Healthbox Go behaves

The Healthbox Go “Sense” app is not only useful for managing Healthbox Go settings, it can also be used to operate it. Several functions are available:

Use silent settings to reduce the flow rate in accordance with your sleep pattern.

Monitor the air quality and check the current ventilation status.

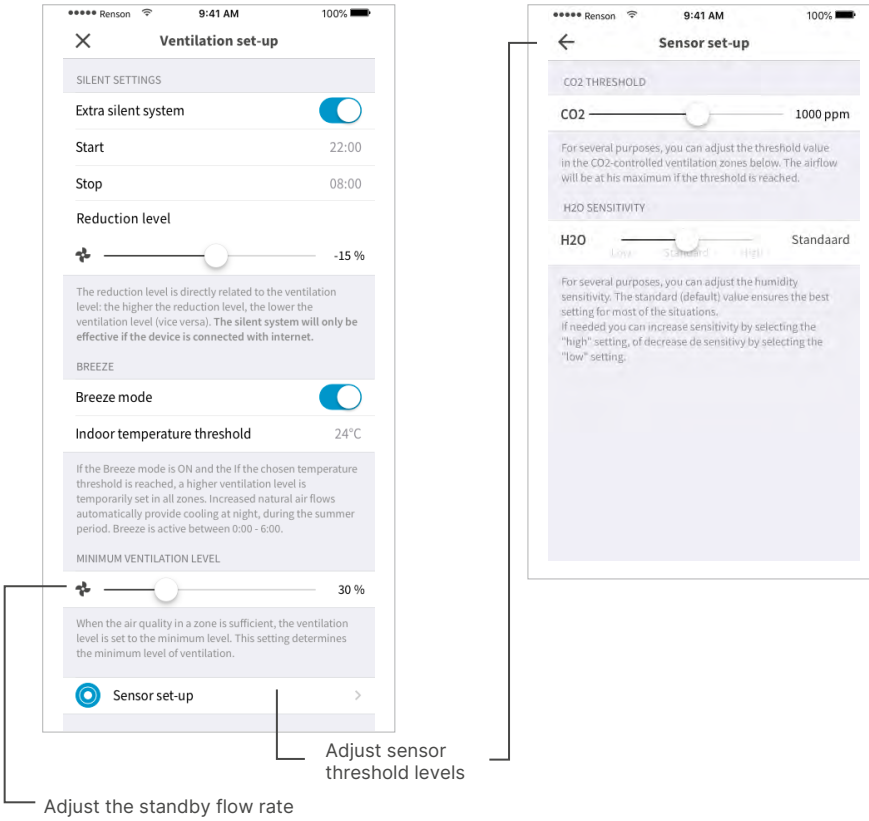

Temporarily reduce the air flow rate or start a boost via the app.

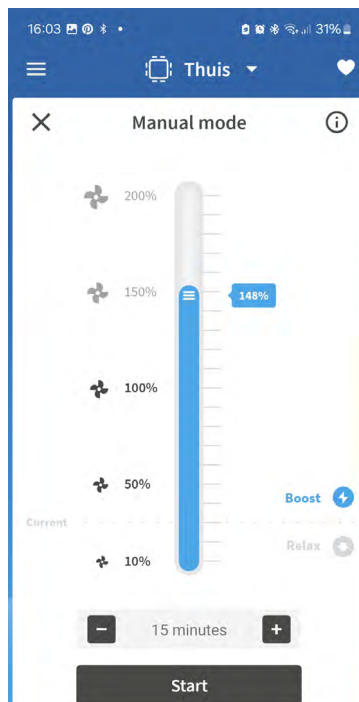

USER

8.2 • Setting up WPS (Wi-Fi Protected Setup)

Pressing the large control button for 5 seconds will set up the Wi-Fi network for 40 minutes. What's more, the WPS functionality can be used to link the Healthbox Go unit to the local Wi-Fi router.

Follow these steps:

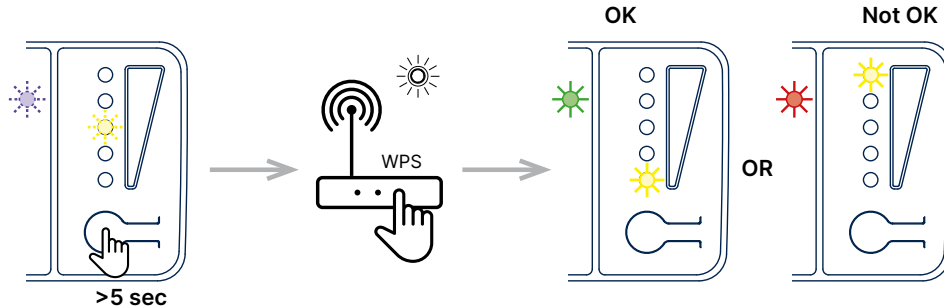

8.3 • XVK3 switch

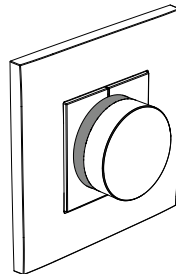

Mode1: Minimum mode/standby flow rate as set, sensor control is inactive. The unit will not ramp up.

Mode2: Normal automatic operation based on the sensors.

Mode3: Boost mode/Increased flow rate: value is taken from the intense profile, this is 120% of the nominal flow rate as set.

Healthbox Go will always return to its standard sensor-controlled operation after a period of 12 hours.

8.4 • Boost using the button on the unit

Pressing the large control button on the Healthbox Go unit will allow you to temporarily increase the air flow rate to the maximum flow rate as set. A different time period can be set, depending on need. The more the button is pressed, the more LEDs light up, the longer the boost will last.

Pressing again will eventually turn off all LEDs and stop the boost.

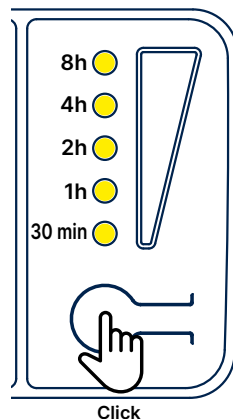

9 • Device malfunction

In the event of a malfunction, such as a faulty sensor or a non-functioning fan, the situation will be displayed clearly:

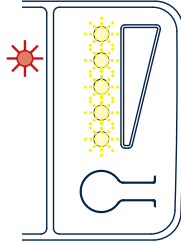

Users can identify the specific cause of the issue by consulting the Sense app.

It seems this is a technical issue that requires the attention of a qualified installer.

Ensure you have all relevant information to hand, such as error codes from the app, or specific symptoms of the defect, to simplify the process and guarantee quick service.

10 • Maintenance

Do not use sprays, abrasives, detergents, solvents or chlorine-containing cleaning agents. These may cause damage to the unit.

Clean the Healthbox Go with a damp cloth and a little solvent-free soap.

10.1 • Fan unit

The fan is fitted with maintenance-free bearings and can function trouble-free for a long time. The fan impeller should be cleaned biannually.

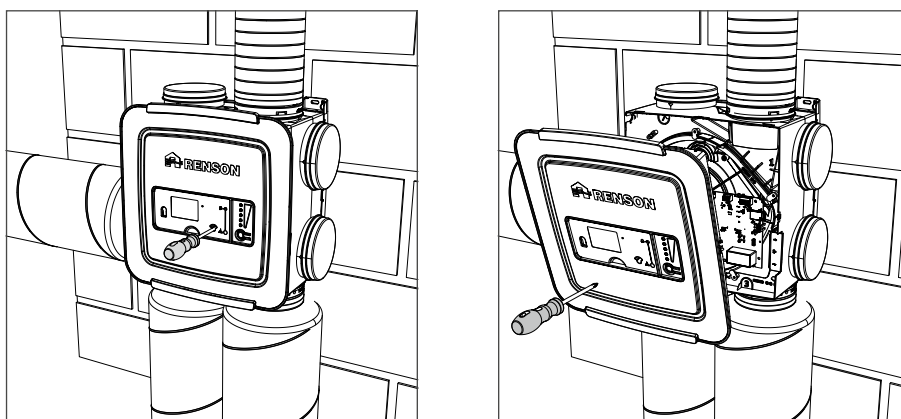

Do this as follows:

- Unplug the power cable from the wall socket or switch off the fuse to deactivate the unit. Measure to check this is actually the case.
- Remove the fan unit cover
- Disconnect the mains power connector from the PCB, as well as any connections to the digital and/or analogue input(s) and output(s).
- Then, use a flathead screwdriver to remove the 5 fastening clips to remove the motor mount with the fan from the housing. Do not touch the PCB!

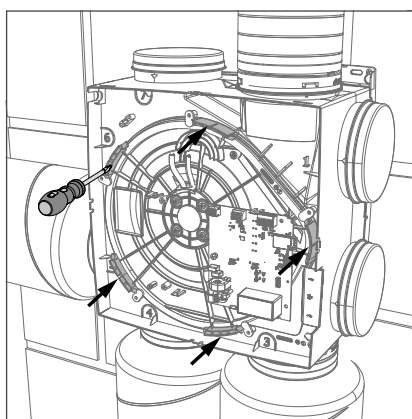

- Clean the fan impeller by blowing it clean with a compressor/pressurised air (do this outdoors). Under no circumstances clean the fan with water and certainly do not immerse it in water or any other cleaning agent.
- Clean the centrifugal fan housing with a wet cloth and then dry the centrifugal housing with a dry cloth.
- Assemble everything in reverse order to the description above.
- Finally, switch the mains voltage to the Healthbox Go back on. After this, the system will boot up on its own.

10.2 • Window vents

- The inlet louvres in the windows should be cleaned annually using a brush or vacuum cleaner.

10.3 • Living space extraction louvres

The extraction louvres in the ventilated rooms should be cleaned annually.

10.4 • Air extraction ducts

It is recommended to have the air ducts mechanically cleaned by an authorised professional every 9 years.

All photos shown are for illustration purposes only and merely serve as an example of a practical situation.
The actual product may vary due to modifications to the product.
Renson® reserves the right to make technical modifications to the products shown.
The most recent brochures are available for download at www.renson.eu



RENSON® NV • Maalbeekstraat 10 • IZ 2 Vijverdam • B-8790 Waregem
Tel. +32 56 30 30 00 • info@renson.be • www.renson.net